

SOLAR DISH ENGINE

1.0 System Description

Dish/engine systems convert the thermal energy in solar radiation to mechanical energy and then to electrical energy in much the same way that conventional power plants convert thermal energy from combustion of a fossil fuel to electricity. As indicated in Figure 1, dish/engine systems use a mirror array to reflect and concentrate incoming direct normal insolation to a receiver, in order to achieve the temperatures required to efficiently convert heat to work. This requires that the dish track the sun in two axes. The concentrated solar radiation is absorbed by the receiver and transferred to an engine.

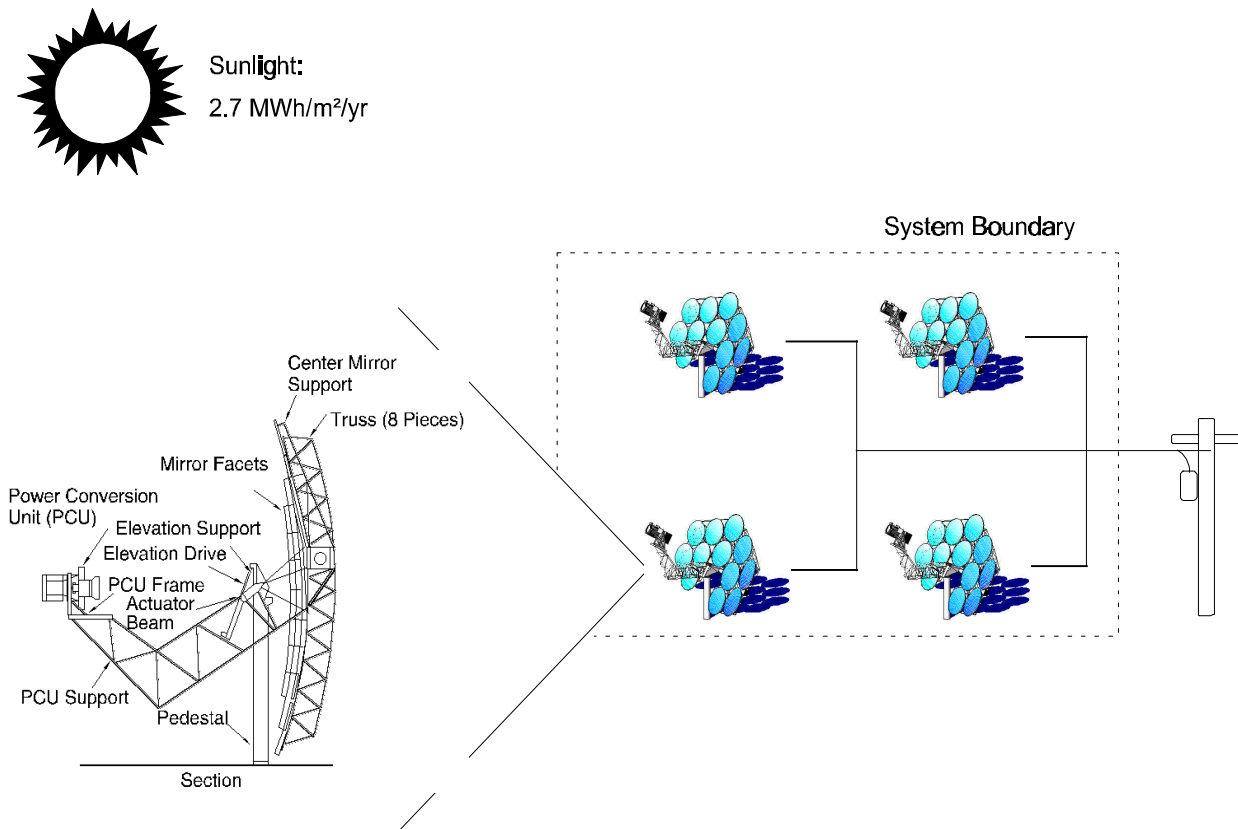

Figure 1. Dish/engine system schematic. The combination of four 25 kW_e units shown here is representative of a village power application

Dish/engine systems are characterized by high efficiency, modularity, autonomous operation, and an inherent hybrid capability (the ability to operate on either solar energy or a fossil fuel, or both). Of all solar technologies, dish/engine systems have demonstrated the highest solar-to-electric conversion efficiency (29.4%)[1], and therefore have the potential to become one of the least expensive sources of renewable energy. The modularity of dish/engine systems allows them to be deployed individually for remote applications, or grouped together for small-grid (village power) or end-of-line utility applications. Dish/engine systems can also be hybridized with a fossil fuel to provide dispatchable power. This technology is in the engineering development stage and technical challenges remain concerning the solar components and the commercial availability of a solarizable engine. The following describes the components of dish/engine systems, history, and current activities.

SOLAR DISH ENGINE

Concentrators

Dish/engine systems utilize concentrating solar collectors that track the sun in two axes. A reflective surface, metalized glass or plastic, reflects incident solar radiation to a small region called the focus. The size of the solar concentrator for dish/engine systems is determined by the engine. At a nominal maximum direct normal solar insolation of 1000 W/m^2 , a 25-kW_e dish/Stirling system's concentrator has a diameter of approximately 10 meters.

Concentrators use a reflective surface of aluminum or silver, deposited on glass or plastic. The most durable reflective surfaces have been silver/glass mirrors, similar to decorative mirrors used in the home. Attempts to develop low-cost reflective polymer films have had limited success. Because dish concentrators have short focal lengths, relatively thin-glass mirrors (thickness of approximately 1 mm) are required to accommodate the required curvatures. In addition, glass with a low-iron content is desirable to improve reflectance. Depending on the thickness and iron content, silvered solar mirrors have solar reflectance values in the range of 90 to 94%.

The ideal concentrator shape is a paraboloid of revolution. Some solar concentrators approximate this shape with multiple, spherically-shaped mirrors supported with a truss structure (Figure 1). An innovation in solar concentrator design is the use of stretched-membranes in which a thin reflective membrane is stretched across a rim or hoop. A second membrane is used to close off the space behind. A partial vacuum is drawn in this space, bringing the reflective membrane into an approximately spherical shape. Figure 2 is a schematic of a dish/Stirling system that utilizes this concept. The concentrator's optical design and accuracy determine the concentration ratio. Concentration ratio, defined as the average solar flux through the receiver aperture divided by the ambient direct normal solar insolation, is typically over 2000. Intercept fractions, defined as the fraction of the reflected solar flux that passes through the receiver aperture, are usually over 95%.

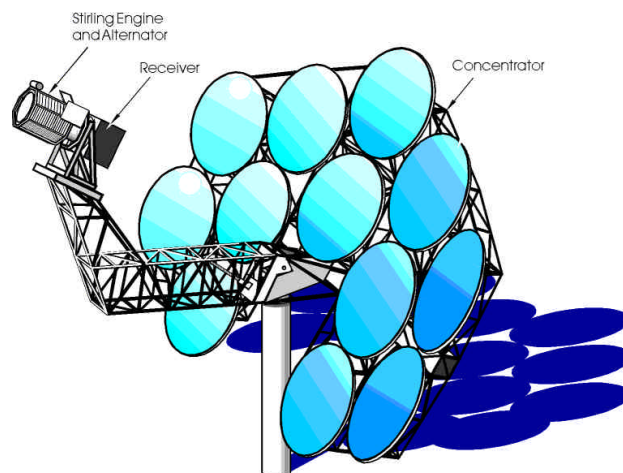

Figure 2. Schematic of a dish/engine system with stretched-membrane mirrors.

Tracking in two axes is accomplished in one of two ways, (1) azimuth-elevation tracking and (2) polar tracking. In azimuth-elevation tracking, the dish rotates in a plane parallel to the earth (azimuth) and in another plane perpendicular to it (elevation). This gives the collector left/right and up/down rotations. Rotational rates vary throughout the day but

SOLAR DISH ENGINE

can be easily calculated. Most of the larger dish/engine systems use this method of tracking. In the polar tracking method, the collector rotates about an axis parallel to the earth's axis of rotation. The collector rotates at a constant rate of 15°/hr to match the rotational speed of the earth. The other axis of rotation, the declination axis, is perpendicular to the polar axis. Movement about this axis occurs slowly and varies by $\pm 23\frac{1}{2}^\circ$ over a year. Most of the smaller dish/engine systems have used this method of tracking.

Receivers

The receiver absorbs energy reflected by the concentrator and transfers it to the engine's working fluid. The absorbing surface is usually placed behind the focus of the concentrator to reduce the flux intensity incident on it. An aperture is placed at the focus to reduce radiation and convection heat losses. Each engine has its own interface issues. Stirling engine receivers must efficiently transfer concentrated solar energy to a high-pressure oscillating gas, usually helium or hydrogen. In Brayton receivers the flow is steady, but at relatively low pressures.

There are two general types of Stirling receivers, direct-illumination receivers (DIR) and indirect receivers which use an intermediate heat-transfer fluid. Directly-illuminated Stirling receivers adapt the heater tubes of the Stirling engine to absorb the concentrated solar flux. Because of the high heat transfer capability of high-velocity, high-pressure helium or hydrogen, direct-illumination receivers are capable of absorbing high levels of solar flux (approximately 75 W/cm²). However, balancing the temperatures and heat addition between the cylinders of a multiple cylinder Stirling engine is an integration issue.

Liquid-metal, heat-pipe solar receivers help solve this issue. In a heat-pipe receiver, liquid sodium metal is vaporized on the absorber surface of the receiver and condensed on the Stirling engine's heater tubes (Figure 3). This results in a uniform temperature on the heater tubes, thereby enabling a higher engine working temperature for a given material, and therefore higher engine efficiency. Longer-life receivers and engine heater heads are also theoretically possible by the use of a heat-pipe. The heat-pipe receiver isothermally transfers heat by evaporation of sodium on the receiver/absorber and condensing it on the heater tubes of the engine. The sodium is passively returned to the absorber by gravity and distributed over the absorber by capillary forces in a wick. Receiver technology for Stirling engines is discussed in Diver et al. [2]. Heat-pipe receiver technology has demonstrated significant performance enhancements to an already efficient dish/Stirling power conversion module [3]. Stirling receivers are typically about 90% efficient in transferring energy delivered by the concentrator to the engine.

Solar receivers for dish/Brayton systems are less developed. In addition, the heat transfer coefficients of relatively low-pressure air along with the need to minimize pressure drops in the receiver make receiver design a challenge. The most successful Brayton receivers have used "volumetric absorption" in which the concentrated solar radiation passes through a fused silica "quartz" window and is absorbed by a porous matrix. This approach provides significantly greater heat transfer area than conventional heat exchangers that utilize conduction through a wall. Volumetric Brayton receivers using honeycombs and reticulated open-cell ceramic foam structures that have been successfully demonstrated, but for only short term operation (tens of hours) [4,5]. Test time has been limited by the availability of a Brayton engine. Other designs involving conduction through a wall and the use of fins have also been considered. Brayton receiver efficiency is typically over 80% [4,5].

SOLAR DISH ENGINE

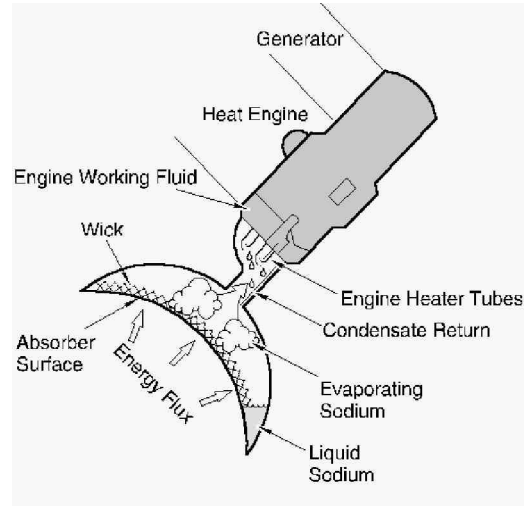

Figure 3. Schematic which shows the operation of a heat-pipe solar receiver.

Engines

The engine in a dish/engine system converts heat to mechanical power in a manner similar to conventional engines, that is by compressing a working fluid when it is cold, heating the compressed working fluid, and then expanding it through a turbine or with a piston to produce work. The mechanical power is converted to electrical power by an electric generator or alternator. A number of thermodynamic cycles and working fluids have been considered for dish/engine systems. These include Rankine cycles, using water or an organic working fluid; Brayton, both open and closed cycles; and Stirling cycles. Other, more exotic thermodynamic cycles and variations on the above cycles have also been considered. The heat engines that are generally favored use the Stirling and open Brayton (gas turbine) cycles. The use of conventional automotive Otto and Diesel engine cycles is not feasible because of the difficulties in integrating them with concentrated solar energy. Heat can also be supplied by a supplemental gas burner to allow operation during cloudy weather and at night. Electrical output in the current dish/engine prototypes is about 25 kW_e for dish/Stirling systems and about 30 kW_e for the Brayton systems under consideration. Smaller 5 to 10 kW_e dish/Stirling systems have also been demonstrated.

Stirling Cycle: Stirling cycle engines used in solar dish/Stirling systems are high-temperature, high-pressure externally heated engines that use a hydrogen or helium working gas. Working gas temperatures of over 700°C (1292°F) and as high as 20 MPa are used in modern high-performance Stirling engines. In the Stirling cycle, the working gas is alternately heated and cooled by constant-temperature and constant-volume processes. Stirling engines usually incorporate an efficiency-enhancing regenerator that captures heat during constant-volume cooling and replaces it when the gas is heated at constant volume. Figure 4 shows the four basic processes of a Stirling cycle engine. There are a number of mechanical configurations that implement these constant-temperature and constant-volume processes. Most involve the use of pistons and cylinders. Some use a displacer (a piston that displaces the working gas without changing its volume) to shuttle the working gas back and forth from the hot region to the cold region of the engine. For most engine designs, power is extracted kinematically by a rotating crankshaft. An exception is the free-piston configuration, where the pistons are not constrained by crankshafts or other mechanisms. They bounce back and forth on springs and the power is extracted from the power piston by a linear alternator or pump. A number of excellent references are available that describe the principles of Stirling machines. The best of the Stirling engines achieve

SOLAR DISH ENGINE

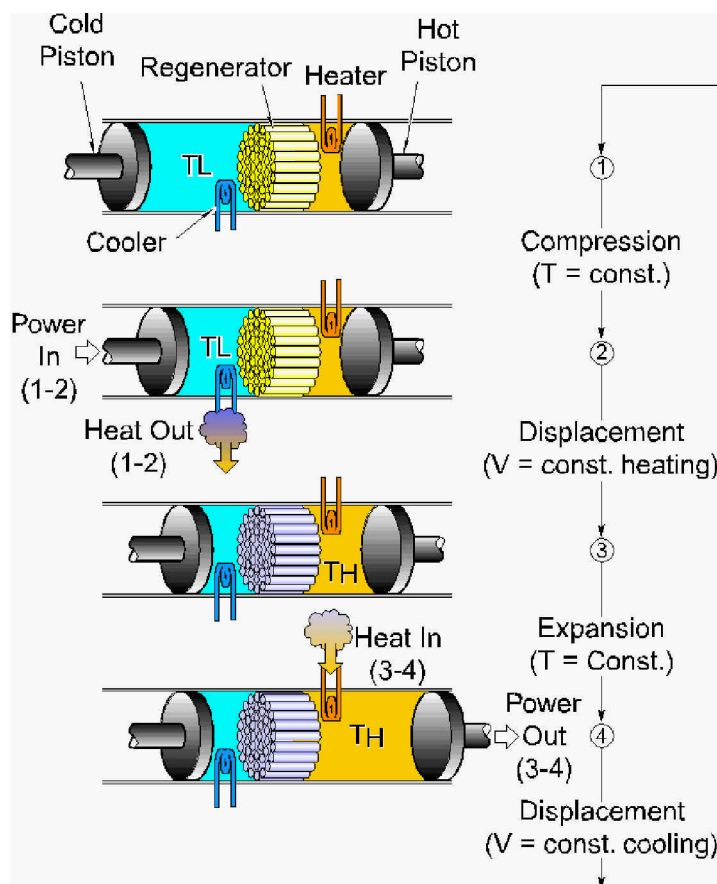

Figure 4. Schematic showing the principle of operation of a Stirling engine.

thermal-to-electric conversion efficiencies of about 40% [6-8]. Stirling engines are a leading candidate for dish/engine systems because their external heating makes them adaptable to concentrated solar flux and because of their high efficiency.

Currently, the contending Stirling engines for dish/engine systems include the SOLO 161 11-kW_e kinematic Stirling engine, the Kockums (previously United Stirling) 4-95 25-kW_e kinematic Stirling engine, and the Stirling Thermal Motors STM 4-120 25-kW_e kinematic Stirling engine. (At present, no free-piston Stirling engines are being developed for dish/engine applications.) All of the kinematic Stirling engines under consideration for solar applications are being built for other applications. Successful commercialization of any of these engines will eliminate a major barrier to the introduction of dish/engine technology. The primary application of the SOLO 161 is for cogeneration in Germany; Kockums is developing a larger version of the 4-95 for submarine propulsion for the Swedish navy; and the STM4-120 is being developed with General Motors for the DOE Partnership for the Next Generation (Hybrid) Vehicle Program.

Brayton Cycle: The Brayton engine, also called the jet engine, combustion turbine, or gas turbine, is an internal combustion engine which produces power by the controlled burning of fuel. In the Brayton engine, like in Otto and Diesel cycle engines, air is compressed, fuel is added, and the mixture is burned. In a dish/Brayton system, solar heat is used to replace (or supplement) the fuel. The resulting hot gas expands rapidly and is used to produce power. In the gas turbine, the burning is continuous and the expanding gas is used to turn a turbine and alternator. As in the

SOLAR DISH ENGINE

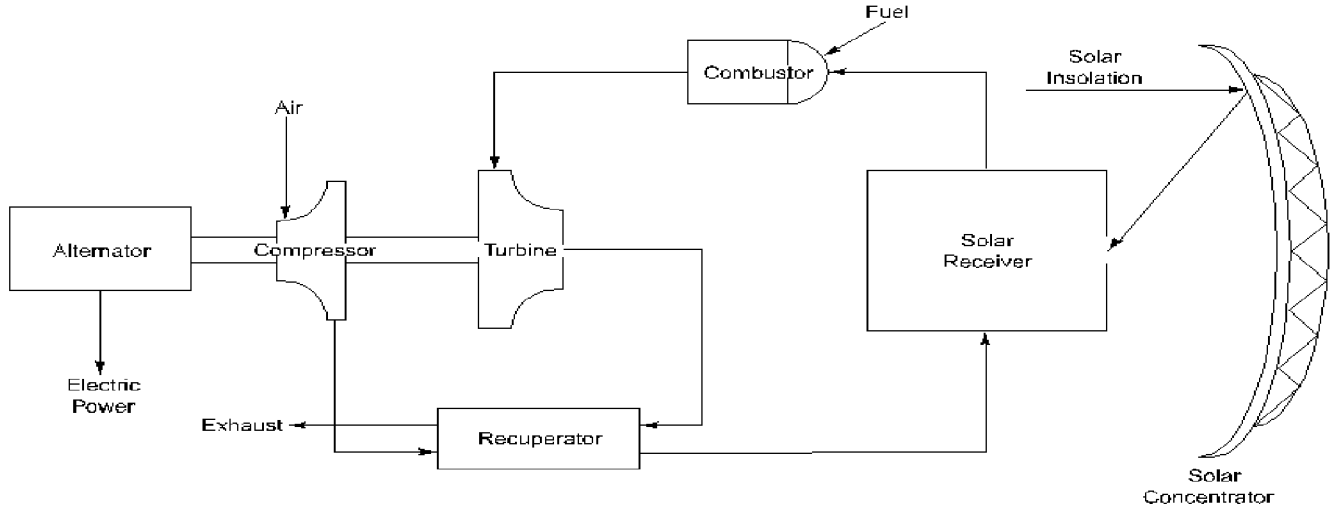

Figure 5. Schematic of a Dish/Brayton system.

Stirling engine, recuperation of waste heat is a key to achieving high efficiency. Therefore, waste heat exhausted from the turbine is used to preheat air from the compressor. A schematic of a single-shaft, solarized, recuperated Brayton engine is shown in Figure 5. The recuperated gas turbine engines that are candidates for solarization have pressure ratios of approximately 2.5, and turbine inlet temperatures of about 850°C (1,562°F). Predicted thermal-to-electric efficiencies of Brayton engines for dish/Brayton applications are over 30% [9,10].

The commercialization of similar turbo-machinery for various applications by Allied Signal, Williams International, Capstone Turbines Corp., Northern Research and Engineering Company (NREC), and others may create an opportunity for dish/Brayton system developers.

Ancillary Equipment

Alternator: The mechanical-to-electrical conversion device used in dish/engine systems depends on the engine and application. Induction generators are used on kinematic Stirling engines tied to an electric-utility grid. Induction generators synchronize with the grid and can provide single or three-phase power of either 230 or 460 volts. Induction generators are off-the-shelf items and convert mechanical power to electricity with an efficiency of about 94%. Alternators in which the output is conditioned by rectification (conversion to DC) and then inverted to produce AC power are sometimes employed to handle mismatches in speed between the engine output and the electrical grid. The high-speed output of a gas turbine, for example, is converted to very high frequency AC in a high-speed alternator, converted to DC by a rectifier, and then converted to 60 hertz single or three-phase power by an inverter. This approach can also have performance advantages for operation of the engine.

Cooling System: Heat engines need to transfer waste heat to the environment. Stirling engines use a radiator to exchange waste heat from the engine to the atmosphere. In open-cycle Brayton engines, most of the waste heat is rejected in the exhaust. Parasitic power required for operation of a Stirling cooling system fan and pump, concentrator drives, and controls is typically about 1 kW_e.

SOLAR DISH ENGINE

Controls: Autonomous operation is achieved by the use of microcomputer-based controls located on the dish to control dish tracking and engine operation. Some systems use a separate engine controller. For large installations, a central System Control and Data Acquisition (SCADA) computer is used to provide supervisory control, monitoring, and data acquisition.

History

Dish/engine technology is the oldest of the solar technologies, dating back to the 1800s when a number of companies demonstrated solar powered steam-Rankine and Stirling-based systems. Modern technology was developed in the late 1970s and early 1980s by United Stirling AB, Advanco Corporation, McDonnell Douglas Aerospace Corporation (MDA), NASA's Jet Propulsion Laboratory, and DOE. This technology used directly-illuminated, tubular solar receivers, the United Stirling 4-95 kinematic Stirling engine developed for automotive applications, and silver/glass mirror dishes. A sketch of the United Stirling Power Conversion Unit (PCU), including the directly illuminated receiver, is shown in Figure 6. The Advanco Vanguard system, a 25 kW_e nominal output module, recorded a record solar-to-electric conversion efficiency of 29.4% (net) using the United Stirling PCU [1,11]. This efficiency is defined as the net electrical power delivered to the grid, taking into account the electrical power needed for parasitics, divided by the direct normal insolation incident on the mirrors. MDA subsequently attempted to commercialize a system using the United Stirling PCU and a dish of their own design. Eight prototype systems were produced by MDA before the program was canceled in 1986 and the rights to the hardware and technology sold to Southern California Edison (SCE). The cancellation of the dish/Stirling program was part of MDA's decision to cancel all of their energy related activities, despite the excellent technical success of their dish/Stirling system. The MDA systems routinely converted sunlight incident on the concentrator's mirrors to electricity with net efficiencies of about 30%. Southern California Edison Company continued to test the MDA system on a daily basis from 1986 through 1988. During its last year of operation,

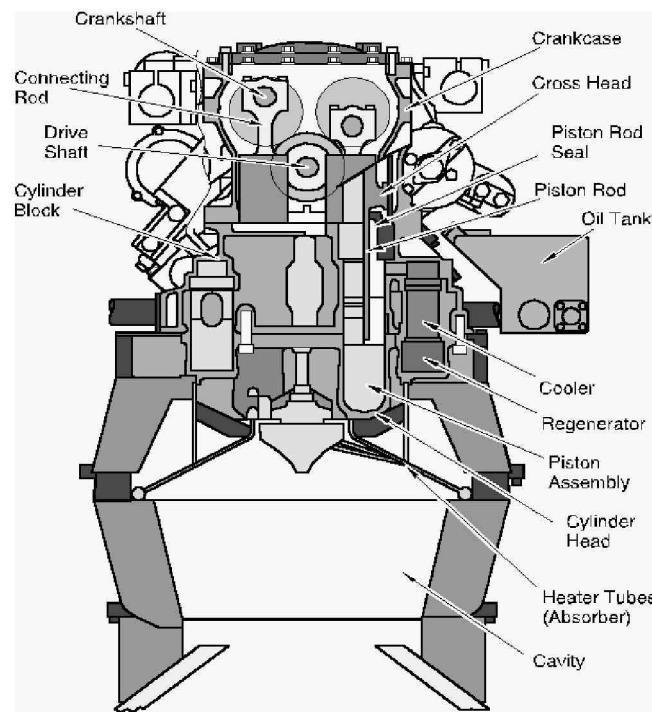

Figure 6. Schematic of the United Stirling 4-95 Kinematic Stirling engine.

SOLAR DISH ENGINE

it achieved an annual efficiency of about 12%, including system outages and all other effects such as mirror soiling. This is also a record for solar energy systems. Without outages, an annual efficiency of over 23% was determined to be achievable [12-15].

In the early 1990s, Cummins Engine Company attempted to commercialize dish/Stirling systems based on free-piston Stirling engine technology. The Cummins development efforts were supported by SunLab through two 50/50 cost shared contracts. (SunLab is a “virtual” laboratory composed of the solar thermal programs at Sandia National Laboratories and the National Renewable Energy Laboratory.) The Dish/Stirling Joint Venture Program (DSJVP) was started in 1991 and was intended to develop a 5 to 10 kW_e dish/Stirling system for remote power applications [16]. The Utility Scale Joint Venture Program (USJVP) was started in late 1993 with the goal of developing a 25 kW_e dish/engine system for utility applications [17]. However, largely because of a corporate decision to focus on its core diesel-engine business, Cummins canceled their solar development in 1996. Technical difficulties with Cummins’ free-piston Stirling engines were never resolved [18].

Current Activities

In 1993, another USJVP contract was initiated with Science Applications International Corporation (SAIC) and Stirling Thermal Motors (STM) to develop a dish/Stirling system for utility-scale applications. The SAIC/STM team successfully demonstrated a 20-kW_e unit in Golden, Colorado, in Phase 1. In December 1996, Arizona Public Service Company (APS) partnered with SAIC and STM to build and demonstrate the next five prototype dish/engine systems in the 1997-1998 time frame. SAIC and Stirling Thermal Motors, Inc. (STM) are working on next-generation hardware including a third-generation version of the STM 4-120, a faceted stretched-membrane dish with a face-down-stow capability, and a directly-illuminated hybrid receiver. The overall objective is to reduce costs while maintaining demonstrated performance levels. Phase 3 of the USJVP calls for the deployment of one megawatt of dish/engine systems in a utility environment, which APS could then use to assist in meeting the requirements of Arizona’s renewable portfolio standard.

The economic potential of dish/engine systems continues to interest developers and investors. For example, Stirling Energy Systems (SES) has purchased the rights of the MDA technology, including the rights to manufacture the Kockums 4-95 Stirling engine. SES is working with MDA to revive and improve upon the 1980s vintage system. There is also interest by Allied Signal Aerospace in applying one of their industrial Brayton engine designs to solar power generation. In response to this interest, DOE issued a request for proposal in the spring of 1997 under the Dish Engine Critical Components (DECC) initiative. The DECC initiative is intended to encourage “solarization” of industrial engines and involves major industrial partners.

Next-generation hybrid receiver technology based on sodium heat pipes is being developed by SunLab in collaboration with industrial partners. Although, heat-pipe receiver technology is promising and significant progress has been made, cost-effective designs capable of demonstrating the durability required of a commercial system still need to be proven. SunLab is also developing other solar specific technology in conjunction with industry.

2.0 System Application, Benefits, and Impacts

Dish/engine systems have the attributes of high efficiency, versatility, and hybrid operation. High efficiency contributes to high power densities and low cost, compared to other solar technologies. Depending on the system and the site, dish/engine systems require approximately 1.2 to 1.6 ha of land per MW_e. System installed costs, although currently over \$12,000/kW_e for solar-only prototypes could approach \$1,400/kW_e for hybrid systems in mass production (see

SOLAR DISH ENGINE

Section 4.0). This relatively low-cost potential is, to a large extent, a result of dish/engine system's inherent high efficiency.

Utility Application

Because of their versatility and hybrid capability, dish/engine systems have a wide range of potential applications. In principle, dish/engine systems are capable of providing power ranging from kilowatts to gigawatts. However, it is expected that dish/engine systems will have their greatest impact in grid-connected applications in the 1 to 50 MW_e power range. The largest potential market for dish/engine systems is large-scale power plants connected to the utility grid. Their ability to be quickly installed, their inherent modularity, and their minimal environmental impact make them a good candidate for new peaking power installations. The output from many modules can be ganged together to form a dish/engine farm and produce a collective output of virtually any desired amount. In addition, systems can be added as needed to respond to demand increases. Hours of peak output are often coincident with peak demand. Although dish/engine systems do not currently have a cost-effective energy storage system, their ability to operate with fossil or bio-derived fuels makes them, in principal, fully dispatchable. This capability in conjunction with their modularity and relatively benign environmental impacts suggests that grid support benefits could be a major advantage of these systems.

Remote Application

Dish/engine systems can also be used individually as stand-alone systems for applications such as water pumping. While the power rating and modularity of dish/engine systems seem ideal for stand-alone applications, there are challenges related to installation and maintenance of these systems in a remote environment. Dish/engine systems need to stow when wind speeds exceed a specific condition, usually at about 16 m/s. Reliable sun and wind sensors are therefore required to determine if conditions warrant operation. In addition, to enable operation until the system can become self sustaining, energy storage (e.g., a battery like those used in a diesel generator set) with its associated cost and reliability issues is needed. Therefore, it is likely that significant entry in stand-alone markets will occur after the technology has had an opportunity to mature in utility and village-power markets.

Intermediate-scale applications such as small grids (village power) appear to be well suited to dish/engine systems. The economies of scale of utilizing multiple units to support a small utility, the ability to add modules as needed, and a hybrid capability make the dish/engine systems ideal for small grids.

Hybridization

Because dish/engine systems use heat engines, they have an inherent ability to operate on fossil fuels. The use of the same power conversion equipment, including the engine, generator, wiring, switch gear, etc., means that only the addition of a fossil fuel combustor is required to enable a hybrid capability. For dish/Brayton systems, addition of a hybrid capability is straightforward. A fossil-fuel combustor capable of providing continuous full-power operation can be provided with minimal expense or complication. The hybrid combustor is downstream of the solar receiver, Figure 5, and has virtually no adverse impact on performance. In fact, because the gas turbine engine can operate continuously at its design point, where efficiency is optimum, overall system efficiency is enhanced. System efficiency, based on the higher heating value, is expected to be about 30% for a dish/Brayton system operating in the hybrid mode.

For dish/Stirling systems, on the other hand, addition of a hybrid capability is a challenge. The external, high-temperature, isothermal heat addition required for Stirling engines is in many ways easier to integrate with solar heat than it is with the heat of combustion. Geometrical constraints makes simultaneous integration even more difficult. As a result, costs for Stirling hybrid capability are expected to be on the order of an additional \$250/kW_e in large scale

SOLAR DISH ENGINE

production. These costs are less than the addition of a separate diesel generator set, for a small village application, or a gas turbine for a large utility application. To simplify the integration of the two heat input sources, the first SAIC/STM hybrid dish/Stirling systems will operate on solar or gas, but not both at the same time. Although, the cost of these systems is expected to be much less than a continuously variable hybrid receiver, their operational flexibility will be substantially reduced. System efficiency, based on higher heating value, is expected to be about 33% for a dish/Stirling system operating in the hybrid mode.

Environmental Impacts

The environmental impacts of dish/engine systems are minimal. Stirling engines are known for being quiet, relative to internal combustion gasoline and diesel engines, and even the highly recuperated Brayton engines are reported to be relatively quiet. The biggest source of noise from a dish/Stirling system is the cooling fan for the radiator. There has not been enough deployment of dish/engine systems to realistically assess visual impact. The systems can be high profile, extending as much as 15 meters above the ground. However, aesthetically speaking they should not be considered detrimental. Dish/engine systems resemble satellite dishes which are generally accepted by the public. Emissions from dish/engine systems are also quite low. Other than the potential for spilling small amounts of engine oil or coolant or gearbox grease, these systems produce no effluent when operating with solar energy. Even when operating with a fossil fuel, the steady flow combustion systems used in both Stirling and Brayton systems result in extremely low emission levels. This is, in fact, a requirement for the hybrid vehicle and cogeneration applications for which these engines are primarily being developed.

3.0 Technology Assumptions and Issues

Dish/engine systems are not now commercially available, except as engineering prototypes. The base year (1997) technology is represented by the 25 kW_e dish-Stirling system developed by McDonnell Douglas Aerospace (MDA) in the mid 1980's using either an upgraded Kockums 4-95 or a STM 4-120 kinematic Stirling engine. The MDA system is similar in projected cost to the Science Applications International Corporation/Stirling Thermal Motors (SAIC/STM) dish/Stirling system, but has been better characterized. The SAIC/STM system is expected to have a peak net system efficiency of 21.9%. The SAIC/STM system uses stretched-membrane mirror modules that result in a lower intercept fraction and a higher receiver loss than the MDA system. However, the lower-cost stretched-membrane design and its improved operational flexibility are projected by SAIC to produce comparably priced systems [19].

Solar thermal dish/engine technologies are still considered to be in the engineering development stage. Assuming the success of current dish/engine joint ventures, these systems could become commercially available in the next 2 to 4 years. The base-year system consists of a dish concentrator that employs silver/glass mirror panels. The receiver is a directly-illuminated tubular receiver. As a result of extensive engineering development on the STM 4-120 and the Kockums engines, near-term technologies (year 2000 and 2005) are expected to achieve significant availability improvements for the engine, thus nearly doubling annual efficiency over the base year technology (from 12 to 23 %). For the years 2010 and on, systems are anticipated to benefit from evolutionary advances in dish concentrator and engine technology. For this analysis, a 10% improvement, compared to the base-year system, is assumed based on the introduction of heat-pipe receiver technology. The introduction of advanced materials and/or the incorporation of ceramics or volumetric absorption concepts could provide significant advances in performance compared to the baseline. Favorable development of advanced concepts could result in improvements of more than an additional 10%. However, because there are no significant activities in these areas, they are not included in this analysis.

SOLAR DISH ENGINE

The system characterized is located in a region of high direct normal insolation ($2.7 \text{ MWh/m}^2/\text{yr}$), which is typified by the Mojave Desert of Southern California. Insolation is consistent with desert regions throughout the Southwest United States.

Research and Development Needs

The introduction of a commercial solar engine is the primary research and development (R&D) need for dish/engine technology. Secondary R&D needs include a commercially viable heat-pipe solar receiver for dish/Stirling, a hybrid-receiver design for dish/Stirling, and a proven receiver for dish/Brayton. All three of these issues are currently being addressed by SunLab and its partners, as part of the DOE Solar Thermal Electric Program. In addition, improvement in dish concentrator components, specifically drives, optical elements, and structures, are still needed and are also being addressed, albeit at a low level of effort. The solar components are the high cost elements of a dish engine system, and improved designs, materials, characterization, and manufacturing techniques are key to improving competitiveness.

Systems integration and product development are issues for any new product. For example, even though MDA successfully resolved many issues for their system, their methods may not apply or may not be available to other designs. Issues such as installation logistics, control algorithms, facet manufacturing, mirror characterization, and alignment methods, although relatively pedestrian, still need resolution for any design. Furthermore, if not addressed correctly, they can adversely affect cost. An important function of the Joint Ventures between SunLab and industry is to address these issues.

Advanced Development Opportunities

Beyond the R&D required to facilitate commercialization of the industrial derivative engines discussed above, there are high-payoff opportunities for engines designed exclusively for solar applications. The Advanced Stirling Conversion System (ASCS) program administered by the National Aeronautics and Space Administration (NASA) Lewis Research Center for DOE between 1986 and 1992, with the purpose of developing a high-performance free-piston Stirling engine/linear alternator, is an example of a high-risk high-payoff development [20]. An objective of the ASCS was to exploit the long life and reliability potential of free-piston Stirling engines.

Thermodynamically, solar thermal energy is an ideal match to Stirling engines because it can efficiently provide energy isothermally at high temperatures. In addition, the use of high-temperature ceramics or the development of "volumetric" Stirling receiver designs, in which a unique characteristic of concentrated solar flux is exploited, are other high-payoff R&D opportunities. Volumetric receivers exploit a characteristic of solar energy by avoiding the inherent heat transfer problems associated with conduction of high-temperature heat through a pressure vessel. Volumetric receivers avoid this by transmitting solar flux through a fused silica "quartz" window as light and can potentially work at significantly higher temperatures, with vastly extended heat transfer areas, and reduced engine dead volumes, while utilizing a small fraction of the expensive high-temperature alloys required in current Stirling engines. Scoping studies suggest that annual solar-to-electric conversion efficiencies in excess of 30% could be practically achieved with potentially lower cost "volumetric Stirling" designs. Similar performance enhancements can also be obtained by the use of high-temperature ceramic components.

SOLAR DISH ENGINE

4.0 Performance and Cost

Table 1 summarizes the performance and cost indicators for the solar dish/engine system being characterized here.

4.1 Evolution Overview

Over the next 5 to 10 years, only evolutionary advances are expected. The economic viability of dish/engine technology will be greatly enhanced if an engine capable of being “solarized” (i.e., integrated with solar energy) is introduced for another application. The best candidates are the STM 4-120 and the Kockums 4-95 kinematic Stirling engines for hybrid vehicles and industrial generators, and the industrial gas turbine/generators. Assuming one of these engines becomes commercial, then commercialization of dish/engine systems at some level becomes likely. With the costs and risks of the critical power conversion unit significantly reduced, only the concentrator, receiver, and controls would remain as issues. Given the operational experience and demonstrated durability and reliability of the remaining solar components, as well as the cost and performance capabilities of dish/engine technology, commercialization may appear attractive to some developers and investors. The modularity of dish/engine systems will help facilitate their introduction. Developers can evaluate prototype systems without the risks associated with multi-megawatt installations.

The commercialization of power towers and, therefore, heliostats (constructed of shared solar components), along with the introduction of a solarizable engine, would essentially guarantee a sizable and robust dish/engine industry. The added manufacturing volumes provided by such a scenario for the related concentrator drives, mirror, structural, and control components would significantly reduce costs and provide an attractive low-cost solar product that will compete in the 25 kW_e to 50 MW_e power market.

4.2 Performance and Cost Discussion

From the above discussion, one of three basic scenarios will happen: (1) no solarizable engine will be commercialized and, therefore, significant commercialization is unlikely, (2) a solarizable engine will be introduced, therefore spawning a fledgling dish/engine business or industry, and (3) a solarizable engine will be introduced and power tower projects will be initiated. Under this scenario, a large and robust solar dish/engine industry will transpire. Of course, numerous variations on the above scenarios are possible but are impossible to predict, much less consider. For the purpose of this analysis, the second scenario is assumed. The cost and performance data in the table reflect this scenario. As discussed in Section 3.0, a STM 4-120 or Kockums 4-95 is assumed to become commercial by 2000, with a dish/engine industry benefiting from mass production. This scenario is consistent with the commercialization plans of General Motors and STM for the STM 4-120.

Although a Brayton engine for industrial generator sets is also a potential positive development, the table considers a dish/Stirling system. A hybrid capability has been included in the table for the year 2000 and beyond. A capacity factor of 50% is assumed. This corresponds to a solar fraction of 50%.

The following paragraphs provide the basis for the cost and performance numbers in the table. System and component costs are from industry sources and independent SunLab analyses. Costs for the MDA system are from [15]. The installed costs include the cost of manufacturing the concentrator and power conversion unit (PCU), shipment to the site, site preparation, installation of the concentrator and PCU, balance of plant (connection to utility grid). The component costs include a 30% profit. These costs are similar to those projected by SAIC at the same

Table 1. Performance and cost indicators.

INDICATOR NAME	UNITS	1980's Prototype		Hybrid System		Commercial Engine		Heat Pipe Receiver		Higher Production		Higher Production	
		1997	+/-%	2000	+/-%	2005	+/-%	2010	+/-%	2020	+/-%	2030	+/-%
Typical Plant Size, MW	MW	0.025		1	50	30	50	30	50	30	50	30	50
Performance													
Capacity Factor	%	12.4		50.0		50.0		50.0		50.0		50.0	
Solar Fraction	%	100		50		50		50		50		50	
Dish module rating	kW	25.0		25.0		25.0		27.5		27.5		27.5	
Per Dish Power Production	MWh/yr/dish	27.4		109.6		109.6		120.6		120.6		120.6	
Capital Cost													
Concentrator	\$/kW	4,200	15	2,800	15	1,550	15	500	15	400	15	300	15
Receiver		200	15	120	15	80	15	90	15	80	15	70	15
Hybrid		----		500	30	400	30	325	30	270	30	250	30
Engine		5,500	15	800	20	260	25	100	25	90	25	90	25
Generator		60	15	50	15	45	15	40	15	40	15	40	15
Cooling System		70	15	65	15	40	15	30	15	30	15	30	15
Electrical		50	15	45	15	35	15	25	15	25	15	25	15
Balance of Plant		500	15	425	15	300	15	250	15	240	15	240	15
Subtotal (A)		10,580		4,805		2,710		1,360		1,175		1,045	
General Plant Facilities (B)		220	15	190	15	150	15	125	15	110	15	110	15
Engineering Fee, 0.1*(A+B)		1,080		500		286		149		128		115	
Project /Process Contingency		0		0		0		0		0		0	
Total Plant Cost		11,880		5,495		3,146		1,634		1,413		1,270	
Prepaid Royalties		0		0		0		0		0		0	
Init Cat & Chem. Inventory		120	15	60	15	12	15	6	15	6	15	6	15
Startup Costs		350	15	70	15	35	15	20	15	18	15	18	15
Other		0		0		0		0		0		0	
Inventory Capital		200	15	40	15	12	15	4	15	4	15	4	15
Land, @\$16,250/ha		26		26		26		26		26		26	
Subtotal		696		196		85		56		54		54	
Total Capital Requirement		12,576		5,691		3,231		1,690		1,467		1,324	
Total Capital Req. w/o Hybrid		12,576		5,191		2,831		1,365		1,197		1,074	
Operation and Maintenance Cost													
Labor	¢/kWh	12.00	15	2.10	25	1.20	25	0.60	25	0.55	25	0.55	25
Material	¢/kWh	9.00	15	1.60	25	1.10	25	0.50	25	0.50	25	0.50	25
Total	¢/kWh	21.00		3.70		2.30		1.10		1.05		1.05	

Notes:

1. The columns for "+/-%" refer to the uncertainty associated with a given estimate.
2. The construction period is assumed to be <1year for a MW scale system.

SOLAR DISH ENGINE

production rates [19]. These projections are also consistent with similar estimates by Cummins and with projections by SunLab engineers. Because of the proprietary nature of cost information, detailed breakdowns of cost estimates are not available in the public domain. Costs are also extremely sensitive to production rates. The installed costs are, therefore, extremely dependent on the market penetration actually achieved. Operation and Maintenance (O&M) costs are also based on [15]. They take into account realistic reliability estimates for the individual components. They are also reasonably consistent with O&M for the Luz trough plants and large wind farms. Component costs are a strong function of production rates. Production rate assumptions are also provided. The economic life of a dish/engine power plant is 30 years. The construction period is much less than one year.

1997 Technology

The base-year technology (1997) is represented by the 25 kW_e dish-Stirling system developed by McDonnell Douglas (MDA) in the mid 1980s. Similar cost estimates have been predicted for the Science Applications International Corporation (SAIC) system with the STM 4-120 Stirling engine [19]. Southern California Edison Company operated a MDA system on a daily basis from 1986 through 1988. During its last year of operation, it achieved an annual efficiency of 12% despite significant unavailability caused by spare part delivery delays. This annual efficiency is better than what has been achieved by all other solar electric systems, including photovoltaics, solar thermal troughs, and power towers, operating anywhere in the world [13,21]. The base-year peak and daily performance of near-term technology are assumed to be that of the MDA systems. System costs assume construction of eight units. Operation and maintenance (O&M) costs are of the prototype demonstration and accordingly reflect the problems experienced.

2000 Technology

Near-term systems (2000) are expected to achieve significant availability improvements resulting in an annual efficiency of 23%. The MDA system consistently achieved daily solar efficiencies in excess of 23% when it was operational. The low availability achieved with the base-year technology was primarily caused by delays in receiving spare parts and by the lack of a dedicated O&M staff. A 23% annual efficiency is, therefore, a reasonable expectation, assuming Stirling engines are commercialized for other applications, and spare parts and a dedicated staff are available. In addition, near term technologies should see a modest reduction in the cost of the dish concentrator simply as a result of the benefits of an additional design iteration. Prototypes for these near-term technologies were first demonstrated in 1985 by McDonnell Douglas and United Stirling. Similar operational behavior was demonstrated in 1995 by SAIC and STM, although for a shorter test period and a lower system efficiency. O&M costs reflect improvements in reliability expected with the introduction of a commercial engine. Production of 100 modules is assumed. At this production rate, component costs are high, resulting in installed costs of nearly \$5,700/kW_e.

2005 Technology

Performance for 2005 is largely based on one of the solarizable engines being commercialized for a non-solar application (e.g., GM's introduction of the STM 4-120 Stirling engine for use in hybrid vehicles). Use of a production-level engine will have a significant impact on engine cost as well as overall system cost. This milestone will help trigger a fledgling dish/engine industry. A production rate of 2,000 modules per year is assumed. Achieving a high production rate is key to reducing component costs, especially for the solar concentrator.

SOLAR DISH ENGINE

2010 Technology

Performance for years 2010 and beyond is based on the introduction of the heat-pipe solar receiver. Heat-pipe solar receiver development is currently being supported by SunLab in collaboration with industrial partners. The use of a heat-pipe receiver has already demonstrated performance improvements of well over 10% for the STM 4-120 compared to a direct-illumination receiver [1]. While additional improvements in mirror, receiver, and/or engine technology are not unreasonable expectations, they have not been included. This is, therefore, a conservative scenario. A production rate of 30,000 modules per year is assumed.

By 2010 dish/engine technology is assumed to be approaching maturity. A typical plant may include several hundred to over a thousand systems. It is envisioned that a city located in the U.S. Southwest would have several 1 to 50 MW_e installations located primarily in its suburbs. A central distribution and support facility could service many installations. In the table, a typical plant is assumed to be 30 MW_e.

2020-2030 Technology

Production levels for 2020 and 2030 are 50,000 and 60,000 modules per year, respectively. No major advances beyond the introduction of heat pipes in the 2010 time frame are assumed for 2020-2030. However, evolutionary improvements in mirror, receiver, and/or engine designs have been assumed. This is a reasonable assumption for a \$2 billion/year, dish/engine industry, especially one leveraged by a larger automotive industry. The system costs are therefore 20 to 25% less than projected by MDA and SAIC at the assumed production levels. The MDA and SAIC estimates are for their current designs and do not include the benefits of a heat-pipe receiver. In addition, the MDA engine costs are for an engine that is being manufactured primarily for solar applications. Advanced concepts (e.g., volumetric Stirling receivers) and/or materials, which could improve annual efficiency by an additional 10%, have not been included in the cost projections. With these improvements installed costs of less than \$1,000/kW_e are not unrealistic.

5.0 Land, Water and Critical Materials Requirements

Land requirements for dish/engine systems are approximately 1.2-1.6 ha/MW_e. No water is required for engine cooling. In some locations, a minimal amount of water is required for mirror washing. There are no key materials that are unique to dish/engine technology.

6.0 References

1. Washom, B., "Parabolic Dish Stirling Module Development and Test Results," Paper No. 849516, Proceedings of the IECEC, San Francisco, CA (1984).
2. Diver, R.B., C.E. Andraka, J.B. Moreno, D.R. Adkins, and T.A. Moss, "Trends in Dish-Stirling Solar Receiver Design," Proceedings of the IECEC, Reno, NV (1990).
3. Andraka, C.E., et. al., "Solar Heat Pipe Testing of the Stirling Thermal Motors 4-120 Stirling Engine," Paper No. 96306, Proceedings of the IECEC, Washington, D.C. (1996).
4. Sanders Associates, Parabolic Dish Module Experiment, Final Report, Sandia National Laboratories, Albuquerque, NM: 1986. Report SAND85-7007.

SOLAR DISH ENGINE

5. Buck, R., P. Heller, and H. Koch, "Receiver Development for a Dish-Brayton System," Proceedings of the 1996 ASME International Solar Energy Conference, San Antonio, TX (1996).
6. Stine, W.B. and R.P. Diver, A Compendium of Solar Dish/Stirling Technology, Sandia National Laboratories, Albuquerque, NM: 1994. Report SAND93-7026 UC-236
7. West, C.D., *Principles and Applications of Stirling Engines*, Van Nostrand Reinhold Company, New York, NY, 1986.
8. Walker, G., *Stirling Engines*, Clarendon Press, Oxford, England, 1980.
9. Weinstein, C.H., "Allied Signal Turbogenerators," Allied Signal Aerospace Equipment Systems Brochure, Torrance CA.
10. Gallup, D.R. and Kesseli, J.B., "A Solarized Brayton Engine Based on Turbo-Charger Technology and the DLR Receiver," Proceedings of the IECEC, AIAA-94-3945-CP, Monterey, CA. (1994).
11. Droher, J.J., and Squier, Performance of the Vanguard Solar Dish-Stirling Engine Module, Electric Power Research Institute, Palo Alto, CA: 1986. Report AP-4608.
12. Lopez, C.W., and K.W. Stone, "Design and Performance of the Southern California Edison Stirling Dish," Proceedings of the 1992 ASME-JSES-KSES International Solar Energy Conference, Maui, HI (1992).
13. Lopez, C.W., and K.W. Stone, Performance of the Southern California Edison Company Stirling Dish, Sandia National Laboratories, Albuquerque, NM: 1993. Report SAND93-7098.
14. Stone, K.W., and R.E. Drubka, "Impact of Stirling Engine Operational Requirements on Dish-Stirling System Life Cycle Costs," Proceedings of the 1994 ASME Solar Energy Conference, San Francisco, CA (1994).
15. Stone, K.W., C.W. Lopez, and R. McAlister, "Economic Performance of the SCE Stirling Dish, Proceedings of the IECEC, Atlanta, Georgia (1993).
16. Bean, J.R., and R.B. Diver, "The CPG 5-kWe Dish/Stirling Development Program," Paper No. 929181, Proceedings of the IECEC, San Diego, CA (1992).
17. Gallup, D.R., T.R. Mancini, J. Christensen, and K. Beninga, "The Utility Scale Joint-Venture Program," Proceedings of the IECEC, AIAA-94-3945-CP, Monterey, CA (1994).
18. Bean, J.R., and R.B. Diver, "Technical Status of the Dish/Stirling Joint Venture Program," Paper No. 95-202, Proceedings of the IECEC, Orlando, FL (1995).
19. Beninga, K, et. al., "Performance Results for the SAIC/STM Prototype Dish/Stirling System," Proceedings of the 1997 ASME International Solar Energy Conference, Washington, D.C. (1997).
20. Shaltens, R.K., and J.G. Schreiber, "Comparison of Conceptual Designs for 25 kWe Advanced Stirling Conversions Systems for Dish Electric Applications," Paper No. 899547, Proceedings of the IECEC, Washington, D.C. (1989).

SOLAR DISH ENGINE

21. Kolb, G.J., "Evaluation of Power Production from the Solar Electric Generating Systems at Kramer Junction: 1988 to 1993," Solar Engineering 1995, Proceedings of the ASME Solar Energy Conference, Maui, HI (1995).